



# Electromagnetic Radiation

## Year 12 Study Notes

Name:

Teacher:

Set:



## **Table of Contents**

The Wave Nature of Light.....	3
Electromagnetic Radiation.....	5
The Particle Nature of Light.....	6
The Photo-electric Effect.....	6
Exercise Set 1: Photo-electric Effect.....	10
Electromagnetic Radiation and Matter.....	13
Bohr's Model of the Atom.....	13
Spectral Analysis.....	17
Fluorescence.....	19
Exercise Set 2: Structure of Matter.....	20
X-rays: Generation, Properties and Applications.....	23
Properties and Applications.....	23
Generating X-rays.....	24
Exercise Set 3: X-rays.....	26

# The Wave Nature of Light

Various light related phenomena are easily explained in terms of wave behaviour:

- ✓ Reflection
- ✓ Refraction
- ✓ Diffraction
- ✓ Polarization
- ✓ Dispersion
- ✓ Interference
- ✓ Colour

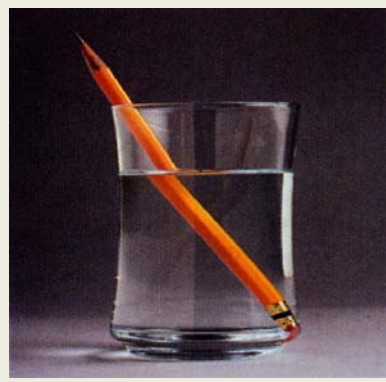

Various wave-model theories to explain the behaviour and properties of light are supported by experimental evidence:

- ✓ HUYGEN'S Wavelets
- ✓ YOUNG'S Fringes
- ✓ FRESNEL'S Bright Spot
- ✓ FRAUNHOFER'S Razor Blades
- ✓ MAXWELL'S Electromagnetic Waves
- ✓ HERTZ'S Sparks
- ✓ LENARD'S photo-electrons
- ✓ PLANCK'S quantum bundles

## HUYGEN'S WAVELETS

-Explains the propagation of waves, reflection, refraction and diffraction.

Each point along the plane wave front is considered a tiny source of new small waves (wavelets) having the same wavelength and frequency as the wave that set the particle vibrating.

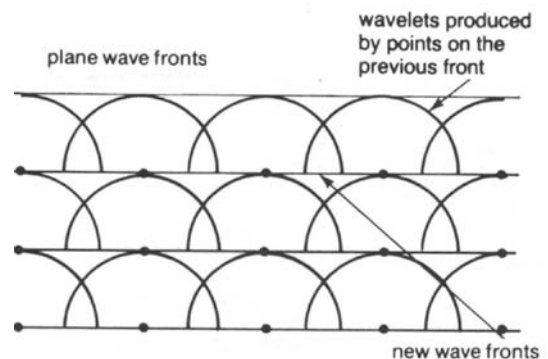

## YOUNG'S FRINGES

-Light demonstrated wave interference behaviour similar to sound and water waves.

Alternating dark and bright fringes (bands) produced by Young's double slit experiment supported the wave superposition principle.

Young also used interference experiments to determine the wavelength of visible light.

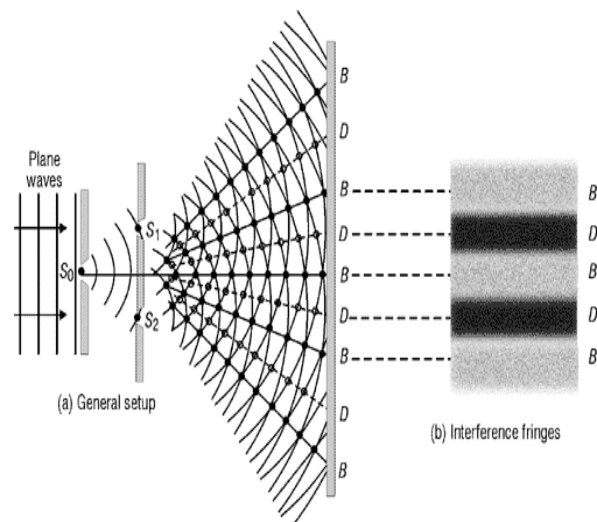

### FRESNEL and POISSON'S BRIGHT SPOT

-the diffraction of light around a solid object to produce a central bright spot within the shadow region supports the wave nature of light.

In addition to the bright spot, there are a series of dark and bright rings formed in the shadow region by the diffraction of light

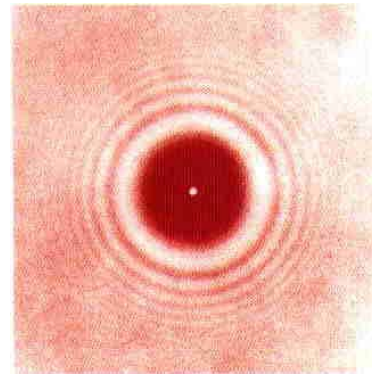

### FRAUHHOFER'S RAZOR BLADES

-the extent of the diffraction of light depends on the relative sizes of the wavelength and the diffracting aperture.

If different wavelengths enter the same aperture shorter wavelengths are diffracted less than longer wavelengths (violet less than red)

Light Diffraction by a Razor Blade

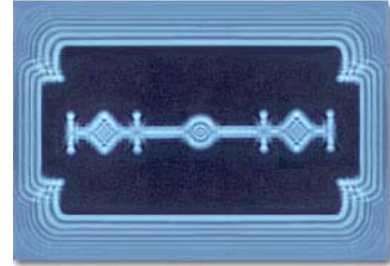

Figure 2

### MAXWELL'S ELECTROMAGNETIC WAVES

-showed that all light was electromagnetic radiation (EMR) consisting of self-propagating electric and magnetic fields.

The E/M fields oscillate perpendicularly to each other and the direction of propagation of light.

Maxwell's theory also provided a theoretical value for the speed of light ( $3 \times 10^8 \text{ ms}^{-1}$ )

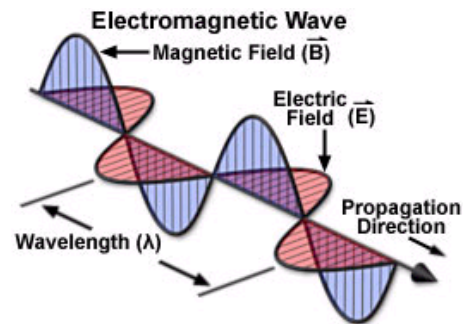

### HERTZ'S Sparks

-showed that light and radio-waves were electro-magnetic radiation (EMR) and supported Maxwell's theories.

When a spark jumped the air gap in one loop, a similar spark was generated in the second

The energy was thereby transferred by EMR.

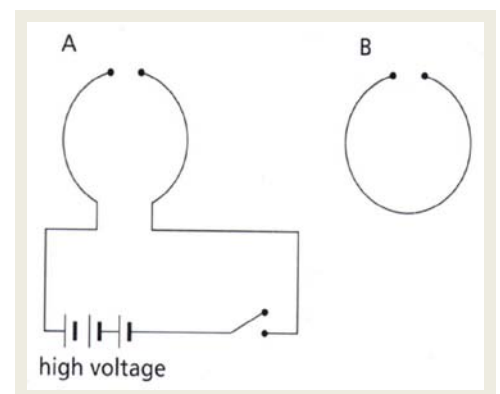

# Electromagnetic Radiation

By the 1860's, investigations being carried out on different types and properties of electromagnetic radiation led to the finding that visible light was itself just one the many forms.

As a form of electro-magnetic radiation, light is part of the electromagnetic spectrum...

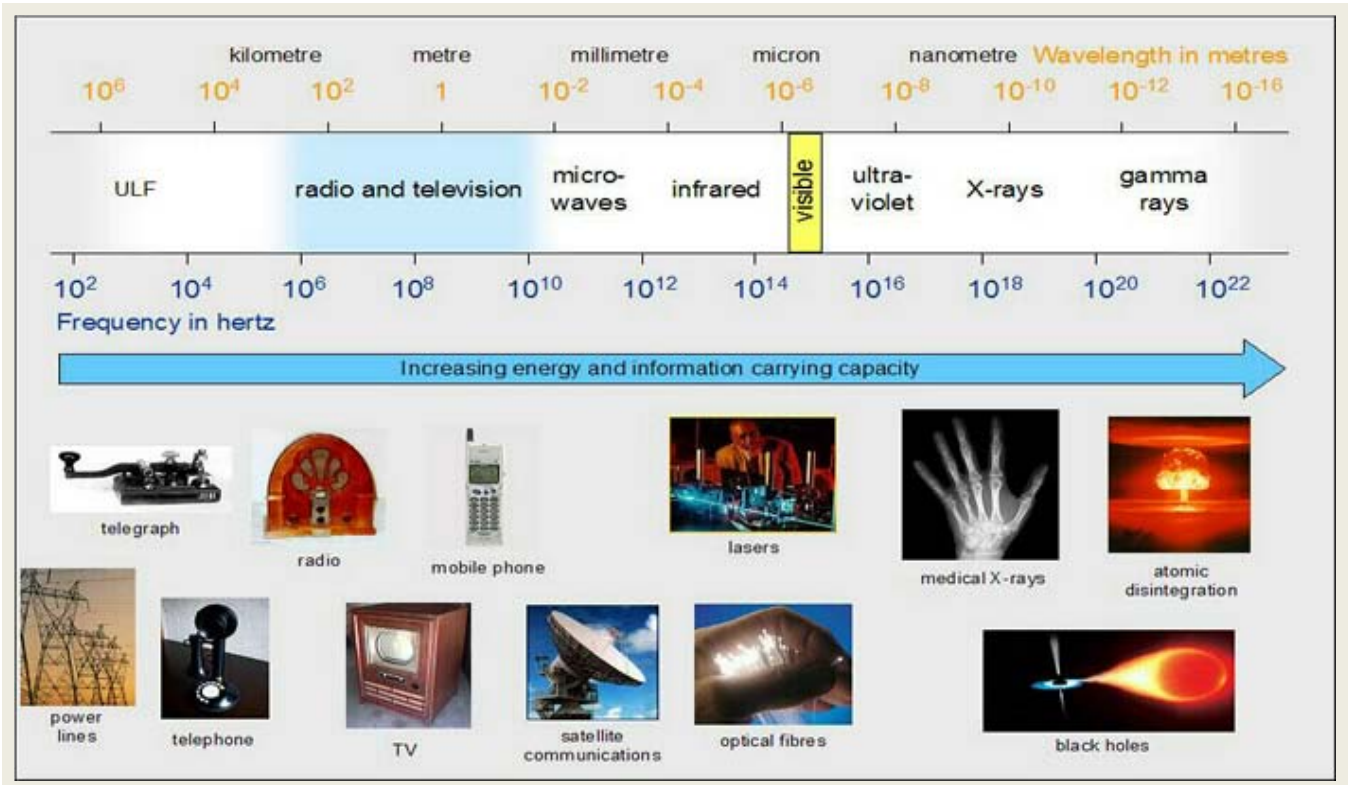

All electromagnetic waves are created by accelerating charges which result in a rapidly changing magnetic and electric fields travelling out from the source at the speed of light.

Since all forms of EMR are essentially electromagnetic waves travelling at the same speed, they differ only by their frequency ( and therefore wavelength).

The energy carried by EMR is proportional to the frequency of the electromagnetic wave.

High frequency (short wavelength) gamma rays are at the high energy end of the EMR spectrum.

Low frequency (long wavelength) radio-waves carry the least energy.

**Problem:** The EMR given off by a sample of sodium as it is burned has a wavelength of 589 nm.  
What is the frequency of this radiation?

---



---



---



---



---



# The Particle Nature of Light

By the mid-nineteenth century, the wave theory of light was fully accepted by theoretical physicists.

However, the discovery of the photo-electric effect in 1887 required some modifications.

Hertz, experimenting with the production and detection of radio-waves, noticed that sparks jump further if a metal surface was illuminated with ultraviolet light.

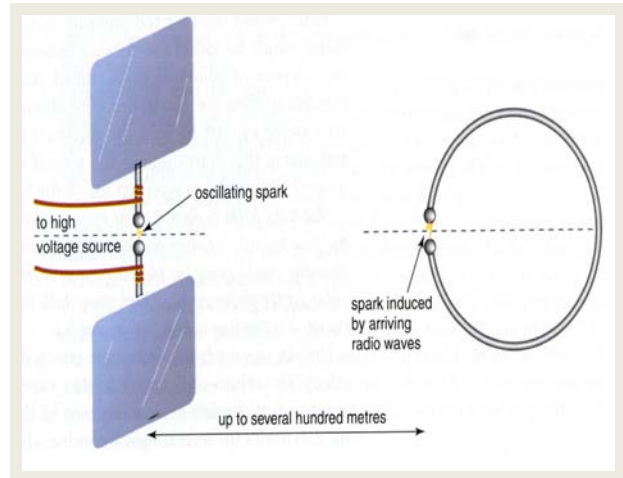

## J.J. THOMPSON'S Photo-electrons

-further investigated the photo-electric effect to discover that when light or any short wavelength EMR shone on a metallic surface, electrons were emitted.

Thomson used the charge to mass ratio to prove that the particles emitted were electrons -called photo-electrons

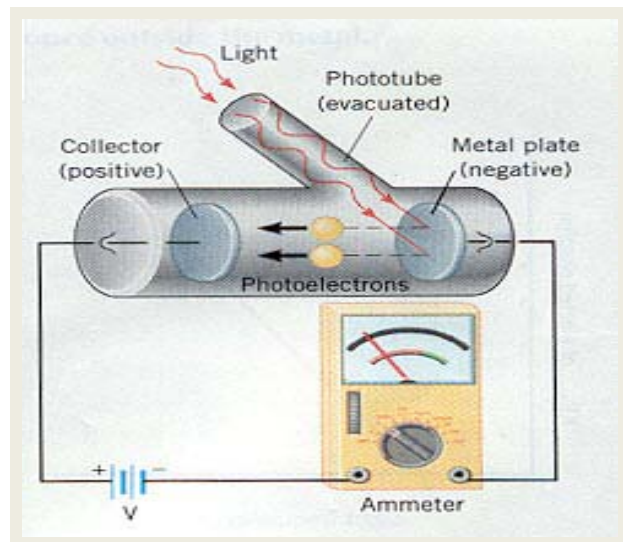

## The Photo-electric Effect

The photo-electric effect can be simply demonstrated by using an electroscope and a clean metal (zinc) plate...

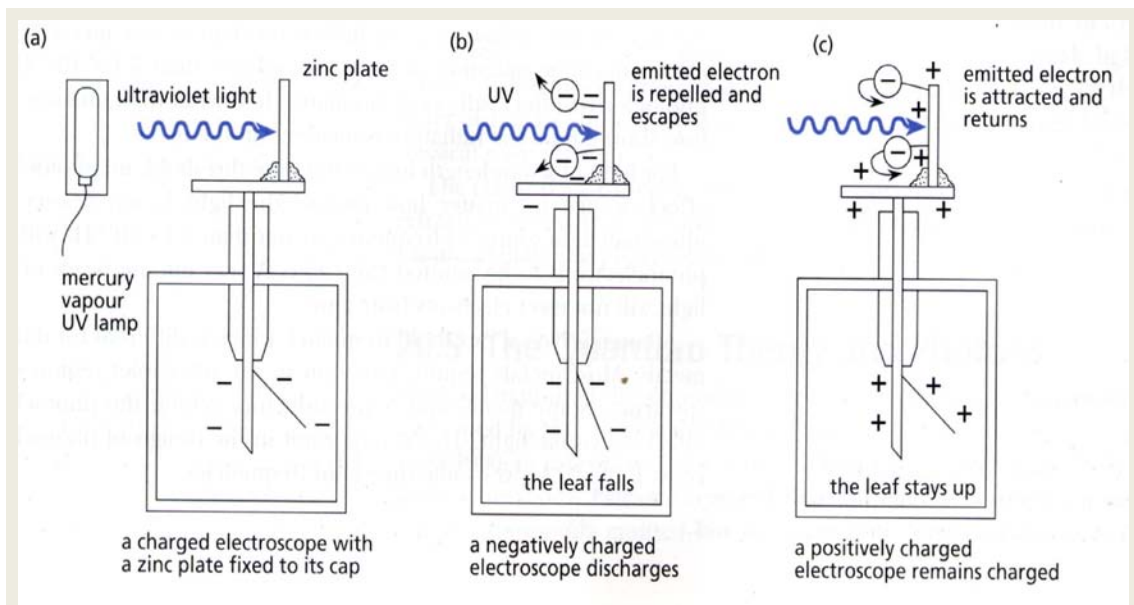

High frequency radiations are more likely to cause the photo-electric effect.

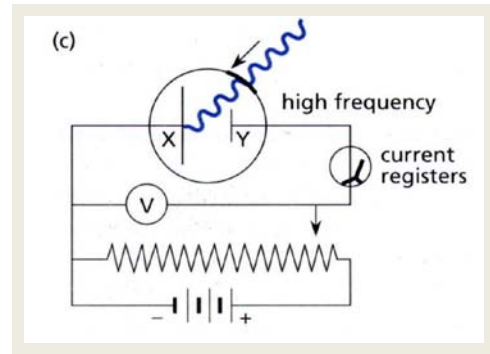
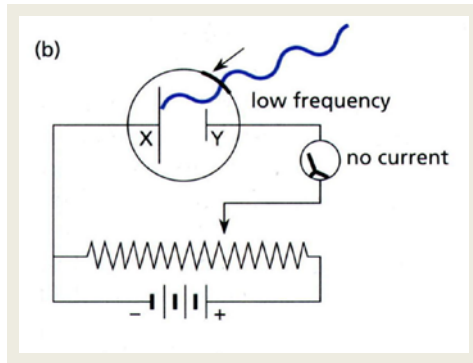

An experimental arrangement illustrating the essential aspects of the photo-electric effect is shown...

A clean metal surface (cathode) is illuminated with a specific external source light...

The frequency (or wavelength) and the intensity of the light source is varied...

If photo-electrons are emitted, they will be detected at the anode...

The photo-electric current is detected by a sensitive ammeter (galvanometer)

A variable voltage sets up an electric field between the electrodes

...photo-electrons are assisted by the field and a maximum current is measured...

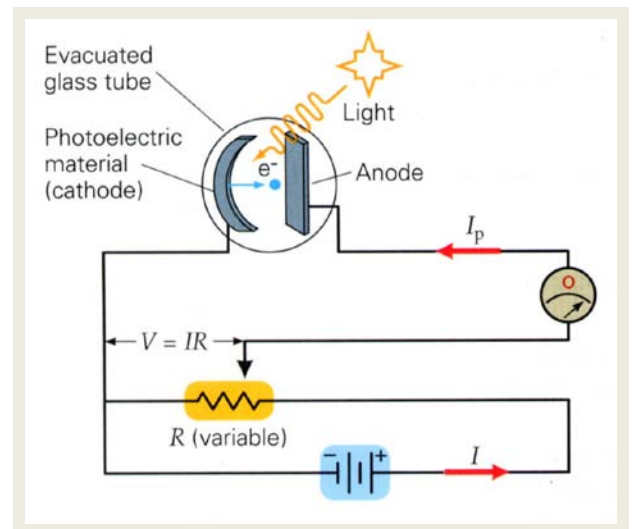

Alternatively, a reverse potential can be set...

...**stopping potential**

...the kinetic energy of the photoelectrons can be measured...

$$W = Vq = E_k = \frac{1}{2}mv^2$$

Note the each metal has the same gradient (Planck's Constant)\*

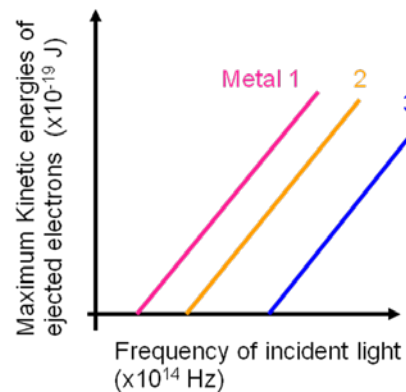

LENARD investigated the photo-electric effect using the apparatus described and discovered that there is a specific frequency (**Threshold Frequency**) below which no photo-electrons are observed.

$$f_x > f_o$$

For light of a frequency greater than the threshold... the rate of photoelectric emission varies directly with the intensity of light.

$$f_x < f_o$$

For light of a frequency less than the threshold frequency... no photoelectrons are emitted no matter how intense the light source.

$$f_x > f_o$$

As long as the incident light was greater than the threshold frequency... photoelectrons are ejected without time delay ( $10^{-9}$  s), regardless of the intensity of light...

LENARD also discovered that at a certain fixed value called the **Stopping Potential** ( $V_0$ ) no photoelectric current will be detected...

photo-electrons have a range of speeds up to a maximum...

$$W = V_0 q_e = E_{k(\max)} = \frac{1}{2} m v_{(\max)}^2$$

As the frequency of light is increased...the maximum kinetic energy of photoelectrons increases proportionally.

The Stopping Voltage depends on the frequency but not the intensity of the light.

LENARD's discoveries were unexpected in terms of classical wave theory.

**PLANCK**, while investigating black body radiation, suggested that the energy was emitted in discrete bursts or "packets" of energy – "quanta"

...rather than continuous emission as classical wave theory predicted...

This led to the quantum theory and a particle model explanation for the photo-electric effect...

**EINSTEIN** provided an explanation of the photo-electric effect using Planck's quantum ideas/research...

EINSTEIN proposed that the energy of light occurs in quantum bundles or "photons"

...each photon has a definite amount of energy that depends only on the frequency:

$$E = h \cdot f$$

...a particle nature of light...

EINSTEIN explained the function of the threshold frequency, suggesting that a certain minimum amount of work was required to remove an electron to the surface of a specific photo-electric metal... "Work Function"

...If an electron is to be emitted, the metal must receive energy equivalent to the threshold energy...

...this energy must be received in one burst or quanta –not as an accumulation of smaller amounts...

...once the threshold is achieved, the balance of energy goes toward increasing the kinetic energy of the photo-electron...

EINSTEIN's explanation can be expressed by the equation:

$$E = h \cdot f = W_f + E_{k(\max)}$$

$E = \text{quanta} = \text{work function} + \text{maximum Kinetic energy}$

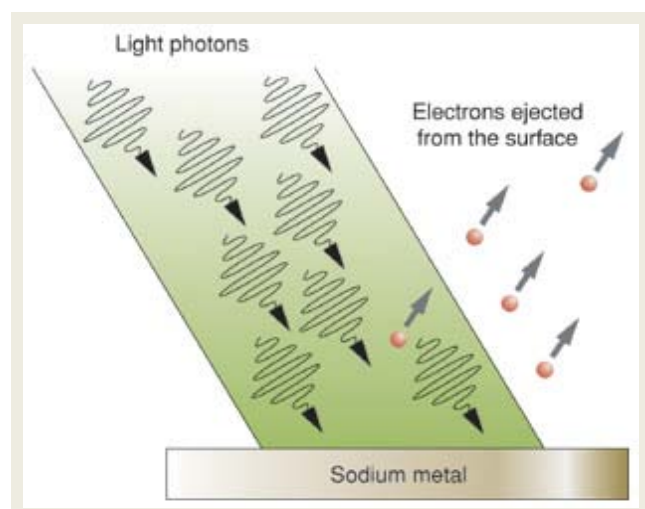
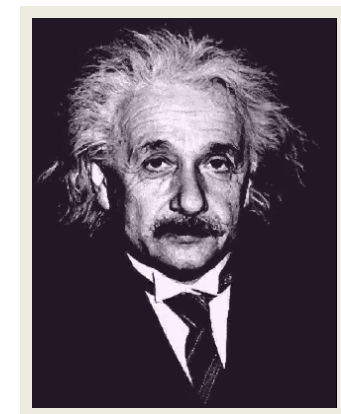
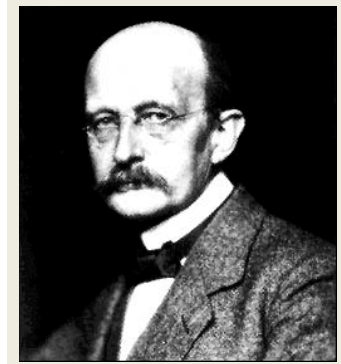



**Type Example 1:** Determine the energy of a photon of orange light that has a frequency of  $5.23 \times 10^{14}$  Hz.

$$\begin{aligned}
 E &= ? & E &= hf \\
 h &= 6.62 \times 10^{-34} \text{ Js} & &= 6.62 \times 10^{-34} \times 5.23 \times 10^{14} \\
 f &= 5.23 \times 10^{14} \text{ Hz} & &= \underline{\underline{3.46 \times 10^{-19} \text{ J}}}
 \end{aligned}$$

**Type Example 2:** What is the wavelength of light if each photon has 1.80 eV of energy. (1 eV =  $1.60 \times 10^{-19}$  J)

$$\begin{aligned}
 \lambda &= ? & E &= hf \text{ but } c = f\lambda \therefore f = \frac{c}{\lambda} \\
 E &= 1.80 \times 1.60 \times 10^{-19} \text{ J} & E &= \frac{hc}{\lambda} \\
 h &= 6.62 \times 10^{-34} \text{ Js} & \lambda &= \frac{hc}{E} \\
 f &= ? & &= \frac{6.62 \times 10^{-34} \times 3.00 \times 10^8}{1.80 \times 1.6 \times 10^{-19}} \\
 c &= 3.00 \times 10^8 \text{ ms}^{-1} & &= \underline{\underline{6.90 \times 10^{-7} \text{ m}}}
 \end{aligned}$$

**Type Example 3:** Determine the velocity of an electron if it has the same energy as a photon of light of frequency  $6.40 \times 10^{14}$  Hz.

$v = ?$

The kinetic energy of the electron equals the energy of the photon where the photon energy =  $hf$

$f = 6.40 \times 10^{14}$  Hz.

$h = 6.62 \times 10^{-34}$  Js

$m_e = 9.11 \times 10^{-31}$  kg

Photon energy

$$E = hf = 6.62 \times 10^{-34} \times 6.40 \times 10^{14} = \underline{\underline{4.24 \times 10^{-19} \text{ J}}}$$

Electron energy

$$E_k = \frac{1}{2}mv^2$$

$$v = \sqrt{\frac{2E_k}{m}} = \sqrt{\frac{2 \times 4.24 \times 10^{-19}}{9.11 \times 10^{-31}}} = \underline{\underline{3.01 \times 10^7 \text{ ms}^{-1}}}$$

**Type Example 4:** An electron requires a minimum energy of 5.60 eV to be ejected from a metal surface. Determine the minimum frequency of the light required to produce photoelectrons.

$$\begin{aligned}
 E &= 5.60 \times 1.60 \times 10^{-19} \text{ J} & E &= hf \\
 h &= 6.62 \times 10^{-34} \text{ Js} & f &= \frac{E}{h} \\
 f &= ? & &= \frac{5.60 \times 1.60 \times 10^{-19}}{6.62 \times 10^{-34}} \\
 & & &= \underline{\underline{1.34 \times 10^{15} \text{ Hz}}}
 \end{aligned}$$

**Problem 1:** A metal is known to have a work function of  $2.84 \times 10^{-19}$  J. Determine:

- a) the threshold frequency;
- b) the longest wavelength of light that will lead to the emission of photoelectrons

---

---

---

---

---

**Problem 2:** What is the maximum velocity of electrons emitted if the metal in the above question is illuminated with light of wavelength  $\lambda = 0.320 \mu\text{m}$

---

---

---

---

---

### Exercise 1: Photoelectric Effect

1. A blue photon of light has energy of 2.60 eV. Determine its frequency and wavelength in vacuum.
2. A photon of yellow light emitted from a mercury discharge tube has a wavelength of 579 nm. Determine the frequency of the photon and its energy in joules and electron volt.
3. The minimum energy (work function) necessary to eject an electron from the surface of aluminium is 4.28 eV. An aluminium sheet is irradiated with ultra violet light with photon energies of 5.50 eV. Determine the longest wavelength that can produce photoemission from aluminium and the maximum kinetic energy of photoelectrons emitted.
4. The work function  $W_{\text{MIN}}$  of uranium is 3.63 eV. Find the longest wavelength which can produce photoelectric emission from this element and the maximum kinetic energy of photoelectrons emitted when uranium is irradiated with photons of 5.00 eV energy.
5. It requires  $7.00 \times 10^{-19}$  J to remove one of the least tightly bound electrons from a chromium surface. a) Find the longest wavelength that will be effective in producing photoelectrons. b) What is the maximum energy of photoelectrons ejected from a chromium surface by UV radiation of  $\lambda = 150 \text{ nm}$ ?
6. Electrons with a maximum energy of 3.51 eV are emitted from a cadmium surface radiated with light of  $\lambda = 200 \text{ nm}$ . a) Find the energy of the incident photons b)  $W_{\text{MIN}}$  the smallest energy which can free an electron from the surface.

7. If  $W_{\text{MIN}} = 2.28 \text{ eV}$ , find the maximum kinetic energy in electron volts of the photoelectrons ejected from a sodium photo-emitter for wavelengths of a) 200 nm b) 300 nm c) 400 nm d) 500 nm. e) What is the longest wavelength which will eject photoelectrons?
8. For each of the following calculate the energy of the photons (in J and eV):  
a)  $f = 1.00 \times 10^{15} \text{ Hz}$  b)  $f = 8.00 \times 10^{19} \text{ Hz}$  c)  $\lambda = 600.0 \text{ nm}$  d)  $\lambda = 1.00 \text{ nm}$
9. Calculate the wavelength and frequency for an x-ray photon of energy  $3.30 \times 10^{-17} \text{ J}$ .
10. Blue light has a wavelength of  $4.50 \times 10^2 \text{ nm}$ . Calculate the energy of:  
a) one photon of blue light b)  $1.00 \times 10^4$  photons of blue light.
11. Determine the ratio of the energy of an x-ray photon of wavelength  $1.00 \times 10^{-10} \text{ m}$  and a radio wave photon of wavelength  $500.0 \text{ m}$ .
12. Yellow light of wavelength  $5.50 \times 10^{-7} \text{ m}$  is emitted from a light globe with a nominal power of  $100 \text{ W}$ . a) How many joules of energy are emitted in  $1.00 \text{ s}$ ?  
b) What is the energy of one photon of yellow light?  
c) How many photons of yellow light are being emitted each second?
13. A radio wave has a wavelength of  $200.0 \text{ m}$  while an x-ray has a wavelength of  $0.200 \text{ nm}$ . Calculate how many radio wave photons would be needed to equal the x-ray's energy.
14. The power output from a light globe is  $20.0 \text{ W}$  at a frequency of  $5.00 \times 10^{14} \text{ Hz}$ . What number of photons are emitted in  $1.00 \text{ minute}$ ?
15. The Sun emits enough light to allow  $1.00 \text{ kW}$  to fall on each square metre of the Earth. If the light has a wavelength of  $550.0 \text{ nm}$ , calculate the number of photons landing on a square kilometre in  $8.00 \text{ h}$ .
16. The human eye can detect yellow light of wavelength  $6.00 \times 10^{-7} \text{ m}$  provided  $1.70 \times 10^{-8} \text{ W}$  are received at the retina. How many photons per second of this light are required for the eye to just see?
17. Radiation of frequency  $7.00 \times 10^{14} \text{ Hz}$  is incident on a metal surface causing photoelectrons to be ejected with a maximum kinetic energy of  $1.30 \times 10^{-19} \text{ J}$ . Find the work function and the threshold frequency for the metal.

## ANSWERS

1.  $6.28 \times 10^{14} \text{ Hz}$ ,  $477 \text{ nm}$
2.  $5.18 \times 10^{14} \text{ Hz}$ ,  $3.43 \times 10^{-19} \text{ J}$ ,  $2.14 \text{ eV}$
3.  $290 \text{ nm}$ ,  $1.22 \text{ eV}$
4.  $342 \text{ nm}$ ,  $1.37 \text{ eV}$
5. (a)  $284 \text{ nm}$  (b)  $3.90 \text{ eV}$
6. (a)  $6.21 \text{ eV}$  (b)  $2.71 \text{ eV}$
7. (a)  $3.92 \text{ eV}$  (b)  $1.85 \text{ eV}$  (c)  $0.82 \text{ eV}$  (d)  $0.2 \text{ eV}$  (e)  $544 \text{ nm}$
8. (a)  $4.1 \text{ eV}$ ,  $6.6 \times 10^{-19} \text{ J}$  (b)  $3.3 \times 10^5 \text{ eV}$ ,  $5.3 \times 10^{-14} \text{ J}$  (c)  $2.1 \text{ eV}$ ,  $3.3 \times 10^{-19} \text{ J}$   
(d)  $1.2 \times 10^3 \text{ eV}$ ,  $2.0 \times 10^{-16} \text{ J}$
9.  $\lambda = 6.03 \times 10^{-9} \text{ m}$ ,  $f = 4.98 \times 10^{16} \text{ Hz}$
10. (a)  $4.42 \times 10^{-19} \text{ J}$  (b)  $4.42 \times 10^{-15} \text{ J}$
11.  $5 \times 10^{12} : 1$
12. (a)  $100 \text{ J}$  (b)  $3.6 \times 10^{-19} \text{ J}$  (c)  $2.8 \times 10^{20}$  photons
13.  $10^{12}$  photons
14.  $3.6 \times 10^{21}$  photons
15.  $7.96 \times 10^{31}$  photons
16.  $5.14 \times 10^{10}$  photons
17.  $W = 3.3 \times 10^{-19} \text{ J}$  ( $2.1 \text{ eV}$ ),  $f_0 = 5.0 \times 10^{14} \text{ Hz}$

## Momentum of Photon

The transfer of photon energy to electrons was central to the photo-electric effect, but photons also have momentum. Paradoxically, both photon energy and momentum, particle properties, are related to the wave properties of light.

## Compton's X-ray Scattering

Direct evidence for the momentum of a photon came from aiming monochromatic X-rays at a small block of graphite.

The X-rays emerged at all angles, and for each angle, there were scattered X-rays of wavelengths.

One had the same angle as the incident X-rays, and the other had a longer wavelength.

The X-rays with identical wavelength can be accounted for by wave theory (reflection).

A photon (particle) perspective is needed to explain the longer wavelength.

Compton found that these scattered X-rays varied with scattering angle, which prompted him to consider the energy transferred by the interaction between photons and matter, and hence a photon momentum.

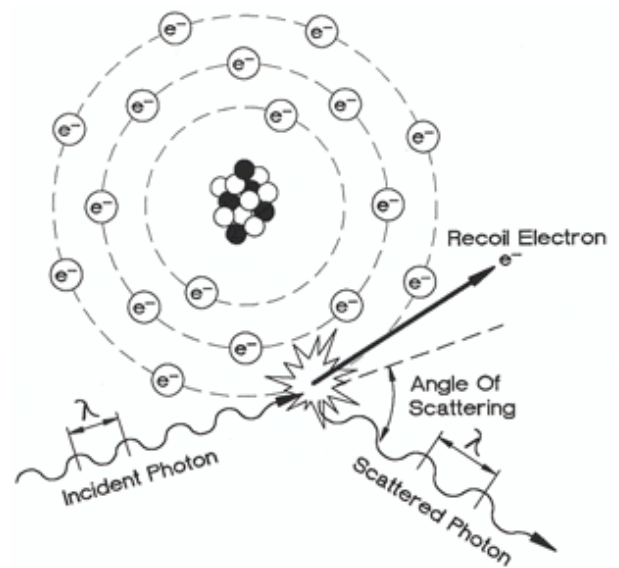

We know that  $E_{\text{photon}} = hf = \frac{hc}{\lambda}$  and is measured in Joules or eV

We also know that  $E_{\text{photon}} = mc^2$  and  $p = mv$

Therefore  $mc^2 = \frac{hc}{\lambda}$

Thus the magnitude of photon momentum  $p = \frac{h}{\lambda}$

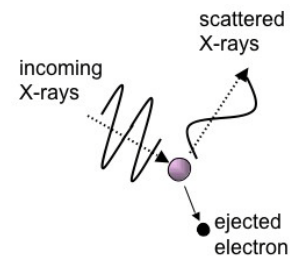

Interactions between light and matter could now be viewed as the energy transfer between two particles colliding.

## The Dual Nature of Light

By the mid 1920's it was accepted that light had a dual nature.

Neither model can explain all behaviour of light.

Each view is supported by significant experimental evidence that can only be explained by one of the models. No experiment has yet been devised that displays both natures simultaneously.

**Problem 1:** What is the momentum of a single photon light having a frequency of  $6.0 \times 10^{14}$  Hz ?

---



---



---



---



---

# Electromagnetic Radiation and Matter

The interaction between light and matter provided physicists with the observational evidence needed to better understand the structure and energy arrangements of atoms...

## Bohr's Model of the Atom

Bohr modified Rutherford's model of the atom, suggesting that electrons associated with an atom were not found in all possible orbits but are only found in certain fixed discrete orbitals of the atom.

Bohr's model of the atom is based on the observed photons associated with the spectral analysis of hydrogen.

Bohr made 3 assumptions about the behaviour of electrons within the hydrogen atom and accurately predicted the frequency of the light in the hydrogen line emission spectrum.

- All electrons within the atom orbit the nucleus in fixed value energy levels...
  - ...energy levels are different for each atom...
  - ...orbiting electrons do not radiate...
- Electrons in one energy level can "jump" to another level by the absorption or emission of a photon...

...the energy of the photon must exactly equal the difference between the two energy levels...

$$E_{\text{photon}} = h \cdot f = (E_2 - E_1)$$

- The angular momentum (L) of an electron in any energy level is a fixed amount...

$$L = m \cdot v \cdot r = n h / 2\pi$$

...where "n" is the energy level number and is referred to as the "principal quantum number"...

- The orbital in which the electron is found is determined by its energy.
- The electron is normally found in the lowest possible orbit closest to the nucleus. The electron is then said to be in its ground state.
- An electron in its ground state may receive energy by absorbing a photon or colliding with bombarding high speed electron.
- When an atom absorbs energy, the electron is elevated to a higher level and the atom is said to be in an excited state.
- The electron in the excited atom returns to the ground state by moving between energy levels of the atom and emits a single photon of radiation equal in energy to the difference between the two levels.

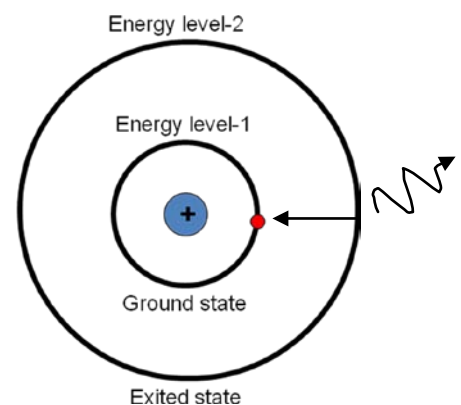
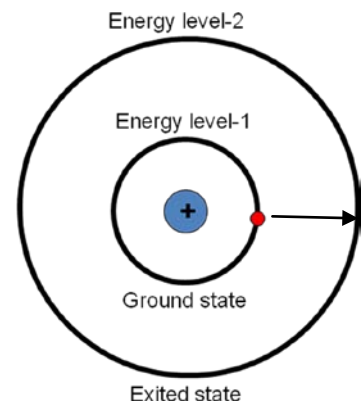
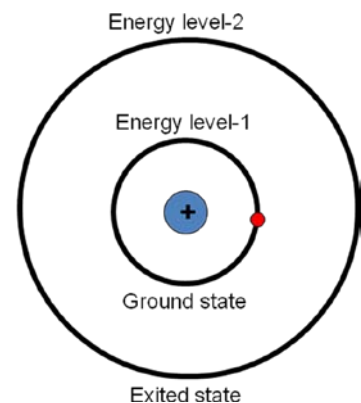
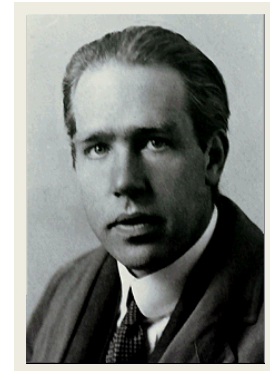



Below is an energy level diagram for the hydrogen atom...

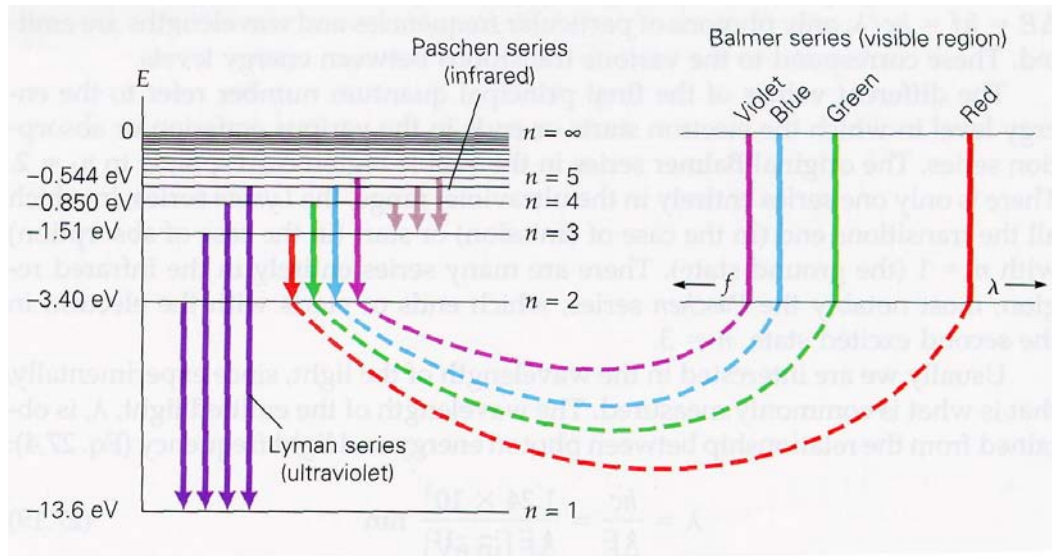

- The lowest energy level ( $n=1$ ) is called the ground state...this is the state that an atom is normally
- The levels above the ground state ( $n = 2$  to  $a$ ) are called "excited states"
- The amount of energy required to completely remove an electron from an atom is known as the ionisation energy.
- Each electron transition from a higher to a lower energy level results in the emission of a photon and a specific spectral line.

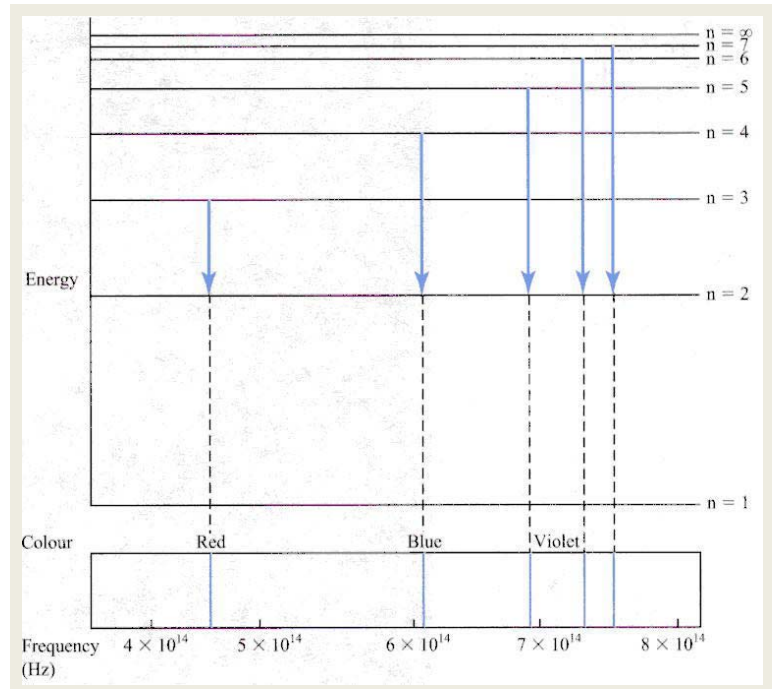
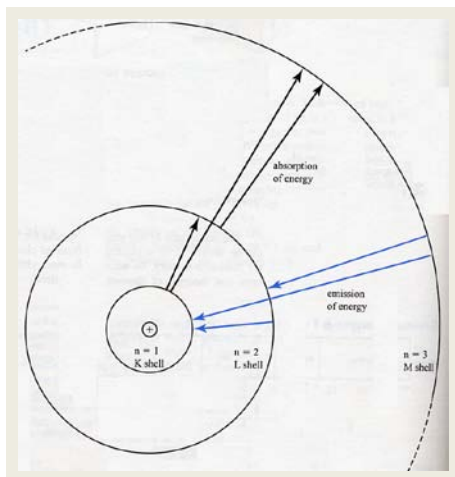

Whilst Bohr's model was a major improvement, the theory was not completely successful.

Bohr's model matches the experimental evidence perfectly for hydrogen and other single electron ions, but fails when applied to more complex atoms.

The complete theory describing the behaviour of electrons within atoms was not clear until the late 1930's with the development of the "quantum theory".

Electrons may be raised to higher energy levels by the absorption of energy from:

- an incident photon
- a collision with a fast moving electron
- thermal excitation

### Incident Photon

Under normal conditions the energy of an absorbed photon must be equal to the energy difference between two energy levels in the atom.

All photon energy must be absorbed in a single electron transition and only from the ground state.

### Collision with a fast moving electron

If struck by a fast moving particle the atom may absorb such parts of the energy necessary to raise an electron between energy levels, the colliding particle thus losing that amount of its energy...

Under normal conditions electrons are in their ground state, thus energy absorbed corresponds to transitions between the ground state and excited states.

If the energy of the photon or fast moving electron is greater than the ionisation energy then the atom will be ionised and any extra energy will be in the form of kinetic energy associated with the ejected electron.

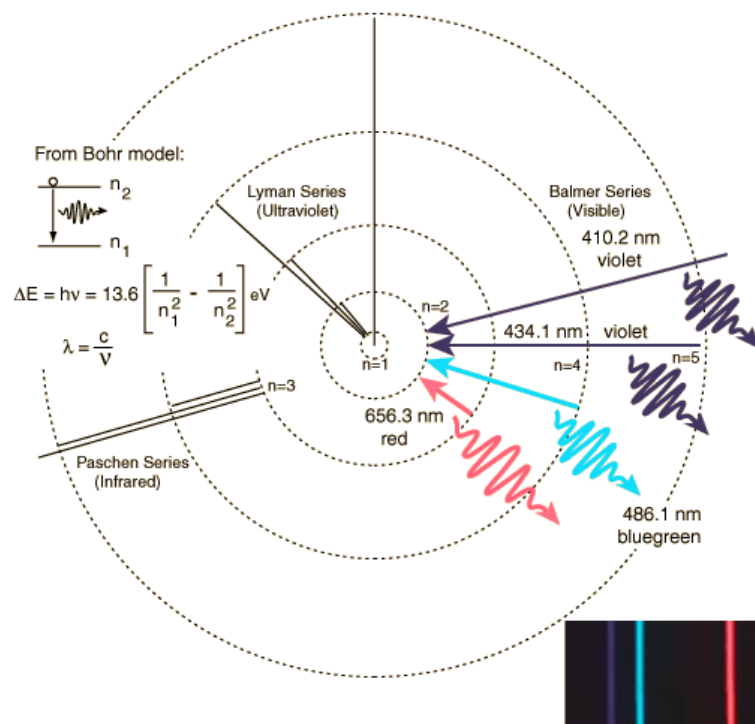

**Type Example 1:** Calculate the frequency of light emitted when an electron moves between energy levels of 4.00 eV and 1.50 eV.

$$E_1 = 4.00 \text{ eV}$$

$$E_2 = 1.50 \text{ eV}$$

$$h = 6.62 \times 10^{-34} \text{ Js}$$

$$hf = \Delta E$$

$$f = \frac{E_1 - E_2}{h} = \frac{2.50 \times 1.60 \times 10^{-19}}{6.62 \times 10^{-34}} = 6.04 \times 10^{14} \text{ Hz}$$

**Type Example 2:** Using the hydrogen energy level diagram:

- (a) determine the frequency of light required to raise an electron to the  $E_3$  level from the ground state;  
 (b) What frequencies of light may be emitted from the excited atom?

$$E_3 \text{ ————— } - 1.5 \text{ eV}$$

$$E_2 \text{ ————— } - 3.4 \text{ eV}$$

$$E_1 \text{ ————— } - 13.6 \text{ eV}$$

$$f = \frac{E}{h} = \frac{E_i - E_f}{h} = \frac{[-1.5 - (-13.6)] \times 1.60 \times 10^{-19}}{6.62 \times 10^{-34}}$$

$$= \mathbf{2.92 \times 10^{15} \text{ Hz}}$$

$$f_{3-1} = 2.92 \times 10^{15} \text{ Hz}$$

$$\text{Also, } f_{3-2} = \frac{-1.5 - (-3.4) \times 1.6 \times 10^{-19}}{6.62 \times 10^{-34}} = \mathbf{4.59 \times 10^{14} \text{ Hz}}$$

$$\text{and, } f_{2-1} = \frac{-3.4 - (-13.6) \times 1.6 \times 10^{-19}}{6.62 \times 10^{-34}} = \mathbf{2.47 \times 10^{15} \text{ Hz}}$$

**Type Example 3:** A photon of wavelength  $1.10 \times 10^2 \text{ nm}$  enters a hydrogen atom.  
 (a) Can it be absorbed by the atom?

$$\lambda = 1.10 \times 10^{-7} \text{ m} \quad E = hf \text{ but } c = f\lambda \therefore f = \frac{c}{\lambda}$$

$$E = ? \quad = \frac{hc}{\lambda} = \frac{6.62 \times 10^{-34} \times 3.00 \times 10^8}{1.10 \times 10^{-7} \times 1.6 \times 10^{-19}} \text{ eV} = 11.28 \text{ eV}$$

$$c = 3.00 \times 10^8 \text{ ms}^{-1}$$

No; the energy is not equal to a transition and not enough to completely remove the electron.

(b) Can an electron with the same energy cause an electron transition. Yes.  $E_1 \rightarrow E_2$

(c) What are the possible recoil velocities of the electron mentioned in part b) ?  
 (i) No transition i.e. an elastic collision.

$m_e = 9.11 \times 10^{-31} \text{ kg}$  All energy remains with the incident electron.

$$v = ? \quad E_k = \frac{1}{2}mv^2 = \mathbf{11.28 \text{ eV}}$$

$$E = 11.28 \text{ eV}$$

$$v = \sqrt{\frac{2 \times 11.28 \times 1.6 \times 10^{-19}}{9.11 \times 10^{-31}}}$$

$$= \mathbf{1.99 \times 10^6 \text{ ms}^{-1}}$$

(ii) Inelastic collision

$$E_k = E_{\text{electron}} - E_{\text{transition } E_1 \rightarrow E_2} = 11.28 - 10.2 = \mathbf{1.08 \text{ eV}}$$

$$\frac{1}{2}mv^2 = 1.08 \text{ eV} \quad v = \mathbf{6.16 \times 10^5 \text{ ms}^{-1}}$$

## Spectral Analysis

A phenomenon of great interest to physicists of the 19<sup>th</sup> century was the production of spectra.

Techniques were developed to cause a gas to emit or absorb certain frequencies of light.

The emitted light is passed through either a prism or a diffraction grating, to produce a series of lines in unique patterns that could be used to identify the gas' chemical composition.

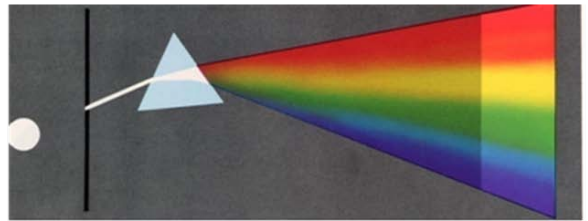

An **emission spectrum** is produced if a gas is energised in some way to produce the light...

The resulting spectrum usually consists of a series of bright lines... -"spectral lines"

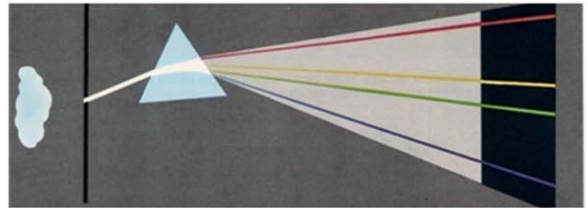

An **absorption spectrum** is created when a beam of white light is passed through a cool sample of gas...

The resulting spectrum usually consists of a **continuous spectrum** of colours with black lines indicating the absorbed frequencies.

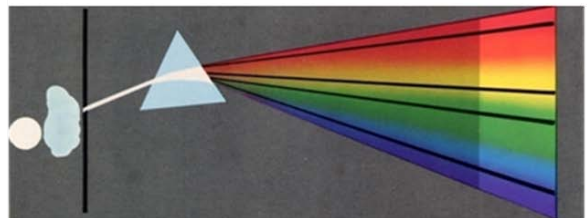

Spectra can be classified as Line, Band and Continuous...

### Line Emission Spectra

A series of coloured lines separated by black spaces are observed...

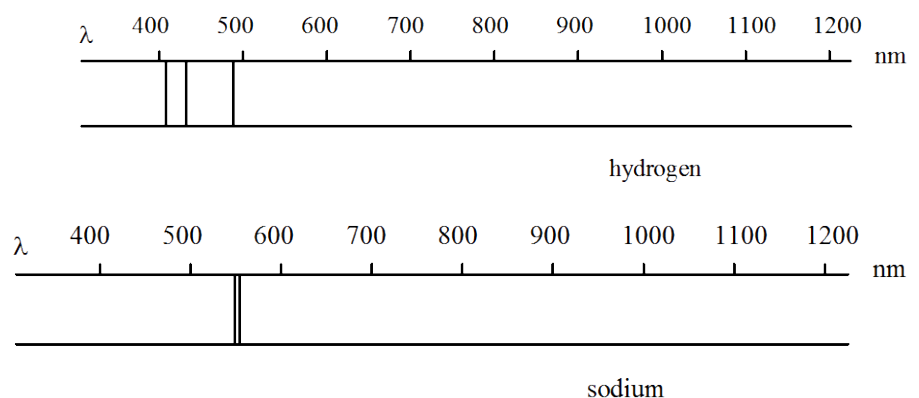
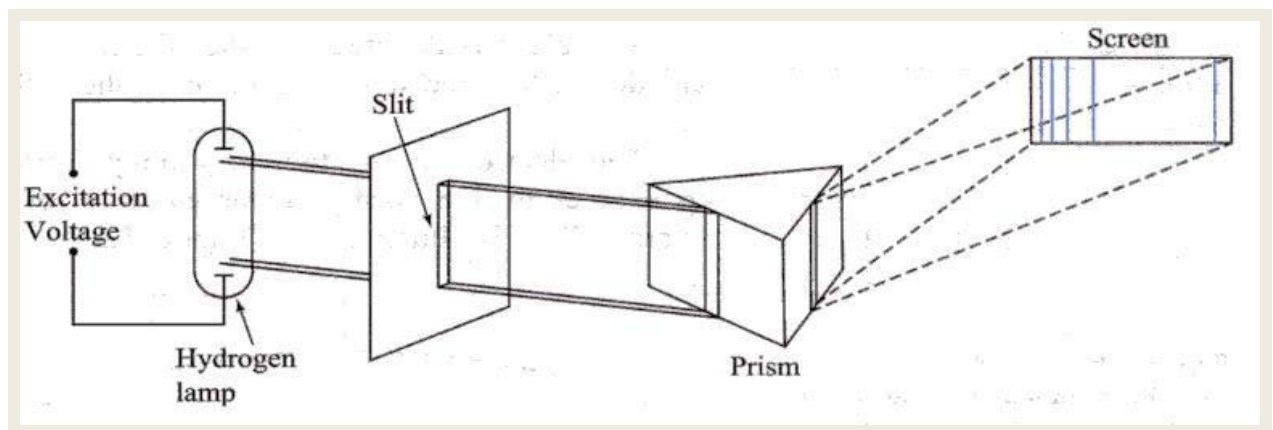

## Line Absorption Spectra

An absorption spectrum results when light passes through a vapour of a substance located between the source and the observer.

Light of specific frequencies are absorbed, resulting in the appearance of dark lines in the spectrum.

The dark lines correspond to frequencies of light absorbed by gaseous atoms when electrons make transitions from the ground state to excited energy levels.

Absorption lines appear in the same position as lines in the emission spectrum.

However not all lines that appear in the emission spectrum appear in the absorption spectrum...why?

Hydrogen Absorption Spectrum

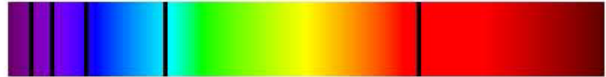

Hydrogen Emission Spectrum

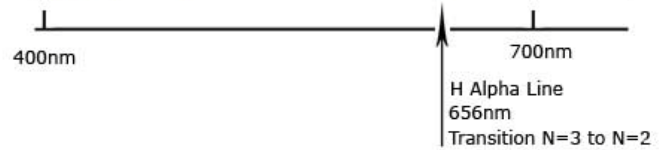

All elements have unique emission or absorption spectra

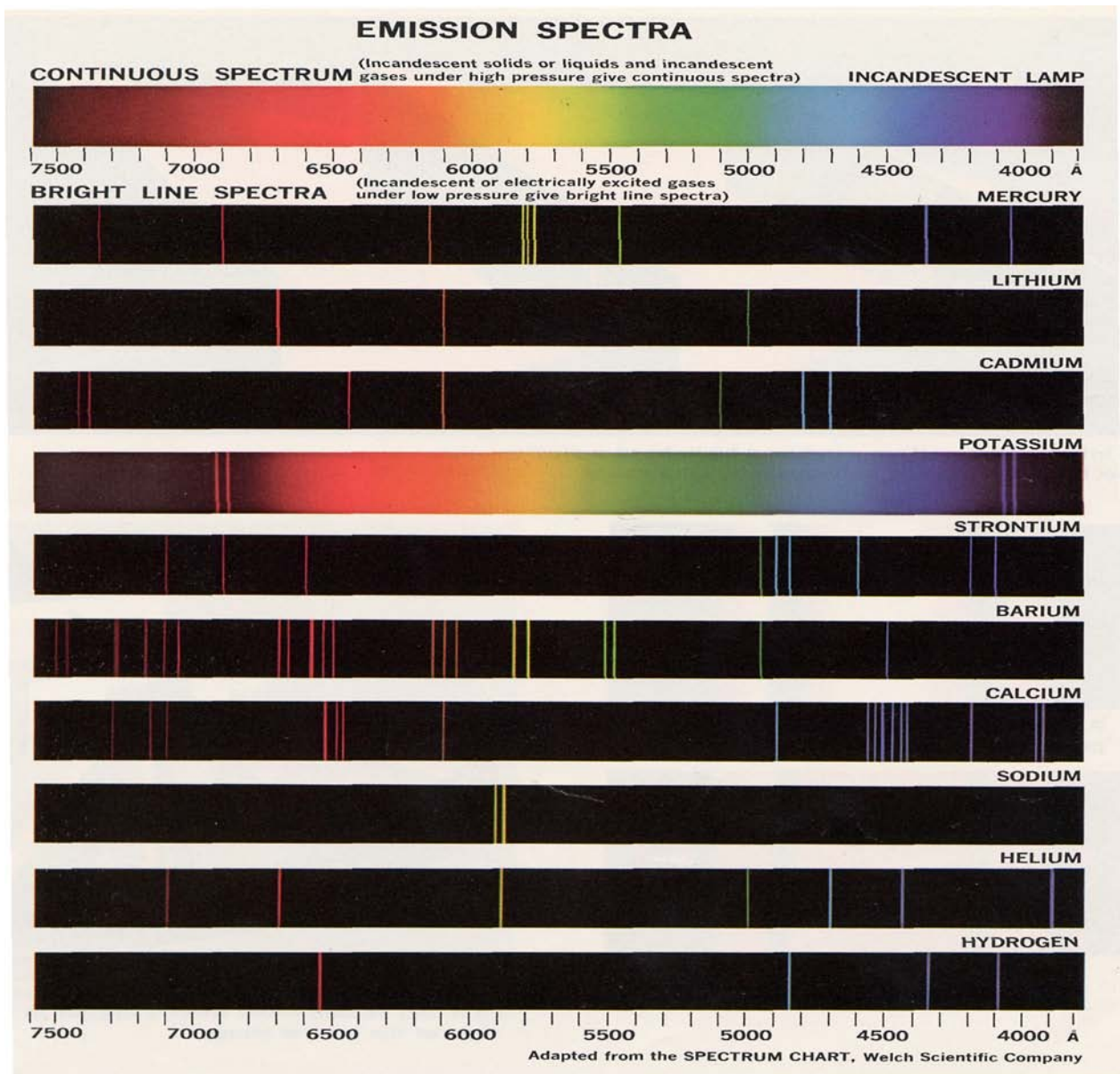



## Fluorescence

Some materials are observed to emit visible light when exposed to particle or electromagnetic radiation.

Fluorescence occurs when an electron is raised to excited states by absorbing a photon or by electron collision.

The excited electron then returns to the ground state by a series of downward transitions which result in the emission of light (photons) in the visible region of the EM spectrum.

When such substances absorb electromagnetic radiation the photons emitted have a lower energy and thus lower frequency than the radiation absorbed.

When invisible (high energy radiation) X-rays or ultraviolet light are used to illuminate a fluorescent material, visible light may then be observed emanating from the sample ie it fluoresces.

Many washing powders contain fluorescent chemicals which fluoresce "white" when exposed to ultraviolet light.

This results in clothes washed using this powder to be "whiter and brighter".

A fluorescent tube is essentially a mercury discharge tube.

As well as the set of discrete frequencies of light emitted in the visible region of the spectrum, a mercury discharge tube emits light in the ultraviolet.

The inside of the tube is coated with a carefully designed mixture of chemical powders, which together emit white light (fluoresce) when exposed to the ultraviolet light.

Fluorescent lamps have been available since the 1940's and are very efficient.

They do not produce as much heat as incandescent light globes and produce the same amount of light for approx. 20% less electrical energy.

They also last longer with expected lives of 20 000 hrs +

Fluorescent materials are used to produce TV and monitor screens.

A narrow beam of electrons is directed onto the screen.

These electrons strike the screen at a point causing fluorescence.

In this case the fluorescence lasts for approximately 50 ms.

The picture which appears on the screen is the result of variations in the intensity of the beam as it sweeps across the screen.

Fluorescent inks can be applied for security checks

Certain minerals in rocks are observed to fluoresce when illuminated by ultraviolet light. By observing the colour of this fluorescence, the identity of the mineral may be determined.

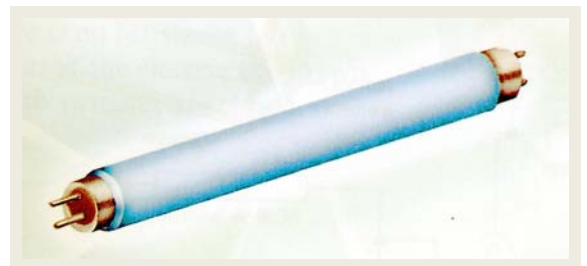

### Type Example

A fluorescent substance is illuminated with light of frequency  $1.57 \times 10^{15}$  Hz. The sample is observed to emit orange light with a wavelength of  $6.00 \times 10^{-7}$  m. Assuming the electron is initially raised to the second excited state by absorbing a photon of the incident light :

- draw an energy level diagram for the atom;
- what type of em radiation "illuminates" the sample?
- what are the possible frequencies of light emitted by the sample and in what region of the electromagnetic spectrum are these frequencies observed?

- a) draw an energy level diagram for the atom

$$f_{\text{incident}} = 1.57 \times 10^{15} \text{ Hz}$$

$$\lambda_{\text{emitted}} = 6.00 \times 10^{-7} \text{ m}$$

#### Energy Calculations

$$E_{\text{incident}} = h f_{\text{incident}}$$

$$= 6.62 \times 10^{-34} \times 1.57 \times 10^{15}$$

$$= 1.039 \times 10^{-18} \text{ J}$$

$$= \mathbf{6.50 \text{ eV}}$$

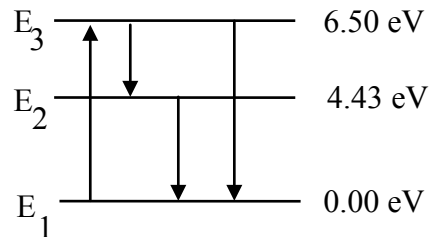

$$E_{\text{emitted}} = \frac{hc}{\lambda_{\text{emitted}}} = \frac{6.62 \times 10^{-34} \times 3 \times 10^8}{6 \times 10^{-7}} = 3.31 \times 10^{-19} \text{ J} = \mathbf{2.07 \text{ eV}}$$

- b) Since the visible spectrum ranges in frequency from approximately  $4 \times 10^{14}$  (red) to  $7.5 \times 10^{14}$  Hz (violet), the incident radiation is in the ultra violet.

c)  $E = hf \therefore f = \frac{E}{h}$

$$f_{E_{3 \rightarrow 1}} = \mathbf{1.57 \times 10^{15} \text{ Hz}}$$

in the ultraviolet

$$f_{E_{2 \rightarrow 1}} = \frac{4.43 \times 1.6 \times 10^{-19}}{6.62 \times 10^{-34}}$$

$$= \mathbf{1.07 \times 10^{15} \text{ Hz}}$$

in the ultraviolet

$$f_{E_{3 \rightarrow 2}} = \frac{2.07 \times 1.6 \times 10^{-19}}{6.62 \times 10^{-34}}$$

$$= \mathbf{5.00 \times 10^{14} \text{ Hz}}$$

in the visible

### Exercise 2: Structure of Matter

- For each of the photons described below, carry out the conversions indicated. What 'type' (e.g. visible, UV, red, etc.) is each photon?
  - 2.0eV, to wavelength
  - 500 nm, to energy
  - 0.30 nm, to frequency
  - 1.0 MeV, to wavelength
- Much of the earliest work on spectra was carried out on hydrogen atoms. In particular Niels Bohr developed a theory explaining the spectrum of hydrogen. How did Bohr explain:
  - the production of emission lines
  - the production of absorption lines
  - the fact that atoms did not continually emit radiation
  - the occurrence of observable series of lines (Balmer, Lyman, Paschen, etc.) in the emission spectrum?

3. One way of representing the emission lines of hydrogen is shown in the diagram.

- Which series (Balmer, Lyman etc.) will feature emission lines with the shortest wavelength?
- The Balmer series are mostly visible. What can you say about the emission lines from the Lyman and Paschen series?

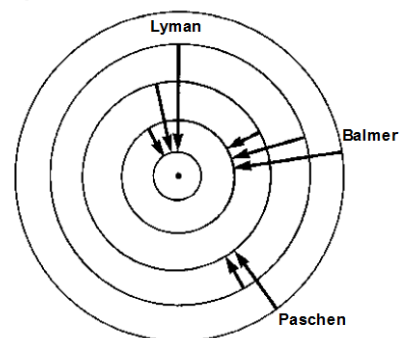

4. The energy levels for the hydrogen atom are shown.

- What is the ionisation energy for hydrogen?
- How much energy must be absorbed by the hydrogen atom for an electron to jump from the ground state to the second excited state?
- A student claims exactly this energy must be delivered by a incident light beam but not by an incident electron beam. Comment on this claim.
- Determine the wavelength of the emission line generated when an electron falls from
  - $n = 3$  to  $n = 2$
  - $n = 3$  to  $n = 1$
  - $n = 2$  to  $n = 1$
- When photons of energy 12.1 eV are fired at hydrogen gas, devices placed around the gas detect photons with seven different energies. Account for this observation.

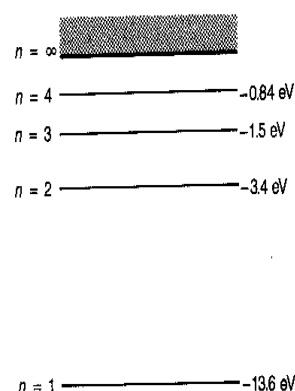

5. Some of the energy levels of the mercury atom are shown in the diagram.

- If an electron with an energy of 6.0 eV collides with a mercury atom in the ground state, what energies might this electron retain?
- How would your answer alter if it was a photon of energy 6.0 eV rather than an electron?
- If a photon of energy 4.9 eV collides with a mercury atom, what could happen?
- What could happen if an electron with energy 12.0 eV collides with a mercury atom?
- How would your answer (d) change if a photon of energy 12.0 eV rather than an electron?

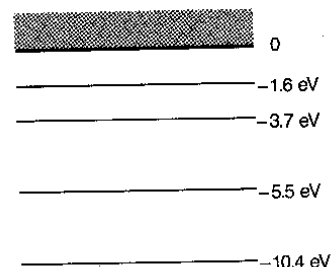

6. One of the most well-known emission spectra is that produced by sodium. One feature of this spectrum is two very close spectral lines. The wavelengths of these lines are 589.0 and 589.6nm. These originate from two very closely spaced energy levels in the sodium atom.

- What colour are these lines?
- Determine the spacing (in eV) of the two energy levels involved.

7. A beam of 3.5 eV electrons is fired at sodium vapour. The kinetic energy of the emitted electrons is measured and found to consist of electrons of energy 3.5 eV, 1.4 eV and 0.30 eV.

- What speed would the incident 3.5 eV electrons have?
- How would you explain each of these emergent energies?
- Sketch a representation of the energy levels of the sodium atom that you can determine from the given information.
- Determine the energy and wavelength of the highest energy photon you would expect to be able to detect emerging.

8. An atom has energy levels at 12.0eV and 15.0eV. If an electron makes a transition from the upper to the lower energy state, determine the frequency of the emitted photon.
9. The energy levels in the hydrogen atom are given by the equation:

$$E_n = \frac{-13.6}{n^2} \text{ (eV) where } n \text{ is the number of the energy level.}$$

- a) What value must  $n$  take for the ground state?  
 b) What does the value -13.6eV correspond to in the hydrogen atom?  
 c) Find the wavelength of the third line of the Balmer series of hydrogen.
10. A radio station sends out a signal of frequency  $1.0 \times 10^6$  Hz. What is the energy difference between the two energy levels responsible for this signal?
11. The sketch below shows some of the lines from a line emission spectrum.

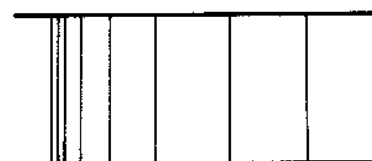

- a) The sketch shows emission lines as dark lines. If the spectrum was drawn as observed through a spectrometer how should emission lines be represented?  
 b) How do these emission lines originate?  
 c) Why are they unequally spaced?  
 d) An expert in emission spectra claims that the diagram represents only one 'series' for a particular element. What does this mean?  
 e) At which end of the diagram do the lines represent the higher wavelengths?
12. a) What is a spectrum?  
 b) Sketch diagrams to illustrate the difference between a continuous emission spectrum and a line emission spectrum.  
 c) How is each produced? Give an example of each.
13. A student claims that a line emission spectrum for a particular element is the same as its line absorption spectrum. What comments would you make in relation to this statement?
14. Generally there are fewer spectral lines in an absorption than the corresponding emission spectrum. How do you account for this?
15. When an absorption spectrum is produced the absorbing atoms become excited. However they rapidly de-excite, emitting the absorbed energy as photons. Why then are dark lines observed across the continuous spectrum?
16. Why do we obtain a continuous spectrum from incandescent solids, rather than a line emission spectrum?

### Answers:

1. a)  $6.2 \times 10^{-7}$ m: red light    b) 2.49eV: green light    c)  $1.0 \times 10^{18}$  Hz: x-rays  
 d)  $1.2 \times 10^{-12}$  m:  $\gamma$ -rays
3. a) Lyman    b) invisible
4. a) 13.6eV    b) 12.1eV    d) i)  $6.54 \times 10^{-7}$ m    d ii)  $1.03 \times 10^{-7}$ m    iii)  $1.22 \times 10^{-7}$ m
5. a) 6.0eV, 1.1eV    b) 6.0eV only    d) ionization
6. a) i) yellow
7. a)  $1.1 \times 10^6$  m.s<sup>-1</sup> (Hint: use  $1/2 mv^2 = qV$ )    d) 3.2eV, 388.5nm
8.  $7.24 \times 10^{14}$ Hz
9. a) 1    b) ionization energy    c) 435.3nm. (Hint: consider  $n = 5$  to  $n = 2$  transition)
10.  $4.1 \times 10^{-9}$ eV

# X-rays: Generation, Properties and Applications

Roentgen (1895) found that when a covered photographic plate placed near a cathode ray tube was then developed, it appeared foggy as if had been exposed to light.

Roentgen deduced that the cathode ray tube, produced an invisible radiation that could penetrate opaque objects.

He called this unknown radiation X-rays.

X-rays are high frequency electromagnetic radiation found between ultraviolet light and gamma rays in the spectrum.

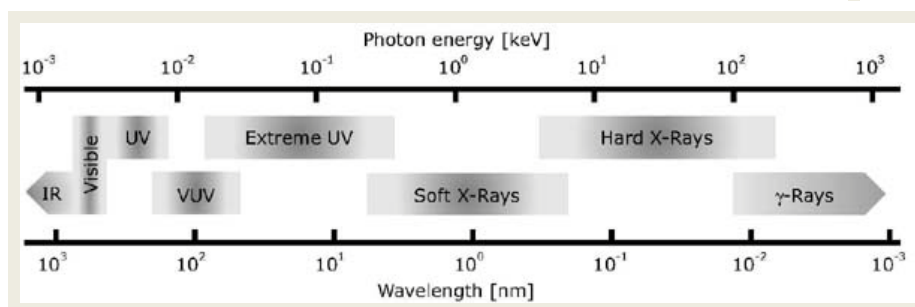
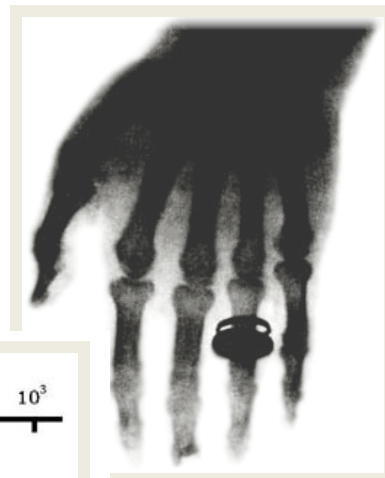

This region of the spectrum has become very important as X-rays have many uses in medicine and industry and because the process of producing of X-rays reveals additional information about the structure of atoms.

The properties and uses of X-rays result from the fact that they are very penetrating electromagnetic radiation with characteristic high frequencies, short wavelength, and large photon energies.

X-ray frequencies range from about  $10^{17}$  to  $10^{19}$  Hz

Also known as "bremsstrahlung"

Low density substances are transparent to X-rays while more dense substances tend to reduce the intensity of (attenuate) X-rays by absorbing them.

The greater the density of the material, the greater the attenuation or absorption.

The higher the photon energy of the X-rays, the less a material will attenuate them.

Soft tissue such as skin and muscle will readily allow the X-rays to pass through them while bone does not (readily).

Controlling the intensity and energy of incident X-radiation, enables the medical practitioners to make X-ray photographs of the interior of their patients including details of the internal structure of individual organs.

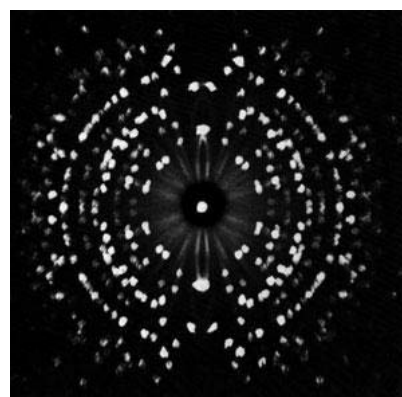



X-rays and low energy gamma rays have enough energy to ionise atoms and molecules and this can damage tissues.

All cells are more sensitive to X-ray damage when they are dividing (DNA).

This sensitivity is exploited when using X-rays to treat cancers.

Protection from X-rays is necessary for anyone who might be frequently exposed

In industry, the penetrating ability of X-rays is used to examine metal joints, such as welds, for imperfections.

The same techniques can be used to examine metal castings, forgings and assembled components for flaws.

X-ray crystallography has allowed research into the structure of complicated minerals and molecules.

The intricate structure of molecules such as DNA has been revealed by X-ray diffraction patterns.

Metal fatigue of metals under repeated stress, can be revealed by X-rays

Even very slight differences in the materials will cause differences in the extent to which the X-rays are attenuated.

This reveals the variations or flaws in the materials if the X-rays are used to make a photograph or an image on a fluorescent screen.

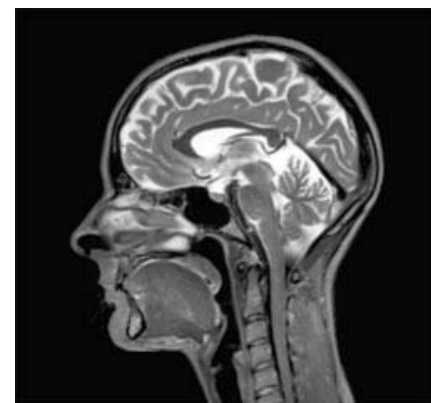
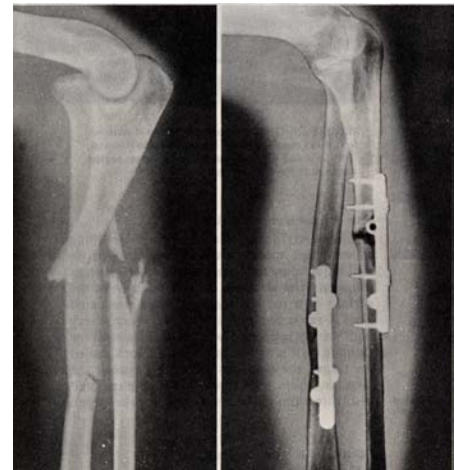

## Generating X-rays

X-rays can be produced when high speed electrons are rapidly decelerated and lose their kinetic energy as high energy electromagnetic radiation...

An example of this occurs when electrons strike a metal plate.

An X-ray tube uses a high voltage to accelerate electrons before they are allowed to strike a metal target and lose their kinetic energy.

A rotating anode (usually tungsten) disc manages the heat and prevents melting.

As a result a continuous spectrum of X-ray energy with features from both the size of the voltage and the specific metal target is produced.

The peaks  $K_{\alpha}$  and  $K_{\beta}$  are characteristic of the metal target and are actually a line spectrum superimposed over the continuous spectrum.

A minimum wavelength, is a due to the 50 kV accelerating voltage.

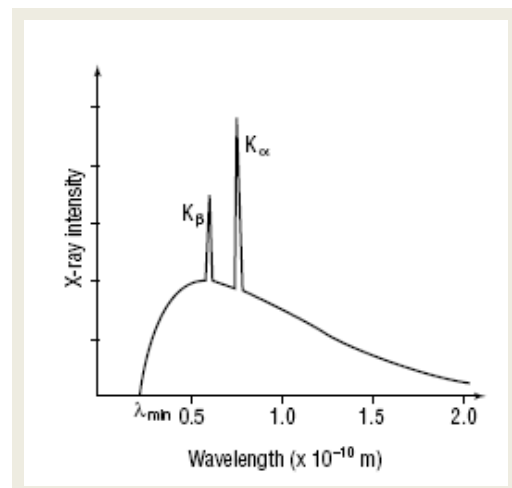
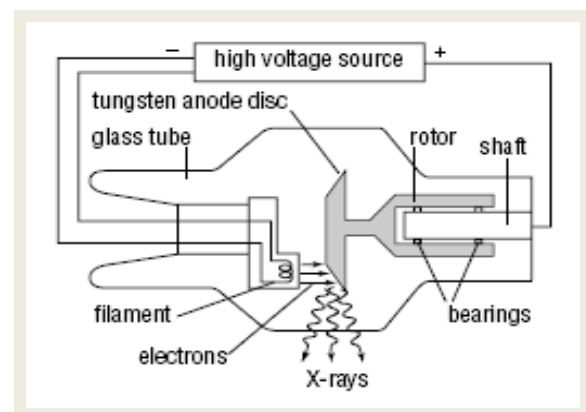

Consider the following schematic diagram of an X-ray tube:

**1.**

The heater voltage heats the cathode and the ejected  $e^-$  s accelerate across to the target anode.

**2.**

The large voltage between the cathode and the anode creates an intense electric field which accelerates the electrons until they strike the target anode.

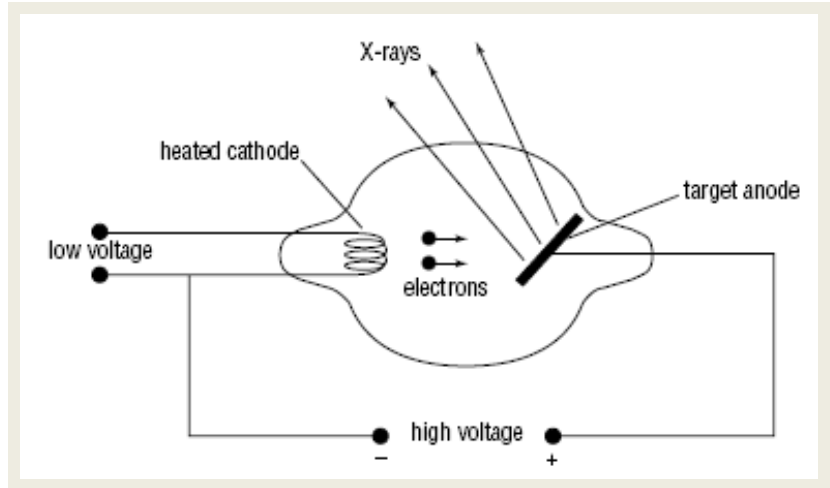

The electrons striking the target have a range of energies and the maximum kinetic energy achieved is equal to the product of the accelerating voltage and the charge on an electron.

$$E_{k(\max)} = V \cdot q_e$$

If an electron collides with the target and stops suddenly, it loses all of its kinetic energy at once and emits a single photon equal to the kinetic energy of the electron.

The most energetic photon obtained from an X-ray tube has a kinetic energy equal to the most energetic electrons accelerated by the voltage.

$$E_{\text{photon}(\max)} = E_{k(\max)}$$

$$h \cdot f_{(\max)} = V \cdot q_e$$

Electrons, when they strike the target, will typically slow down in a number of collisions with individual atoms and lose their energy in more than one step.

Consequently they will create a number of photons each with less energy than the maximum possible photon energy, producing continuous spectra with a wide range of photon energies up to a maximum value.

The characteristic peaks in the X-ray spectra are due to line spectra produced when inner orbital electrons are displaced and replaced by electrons from the higher energy shells.

The sizes of the energy transitions between energy levels or shells vary for different elements. Consequently, the peaks in the X-ray spectrum will be in unique positions for each element.

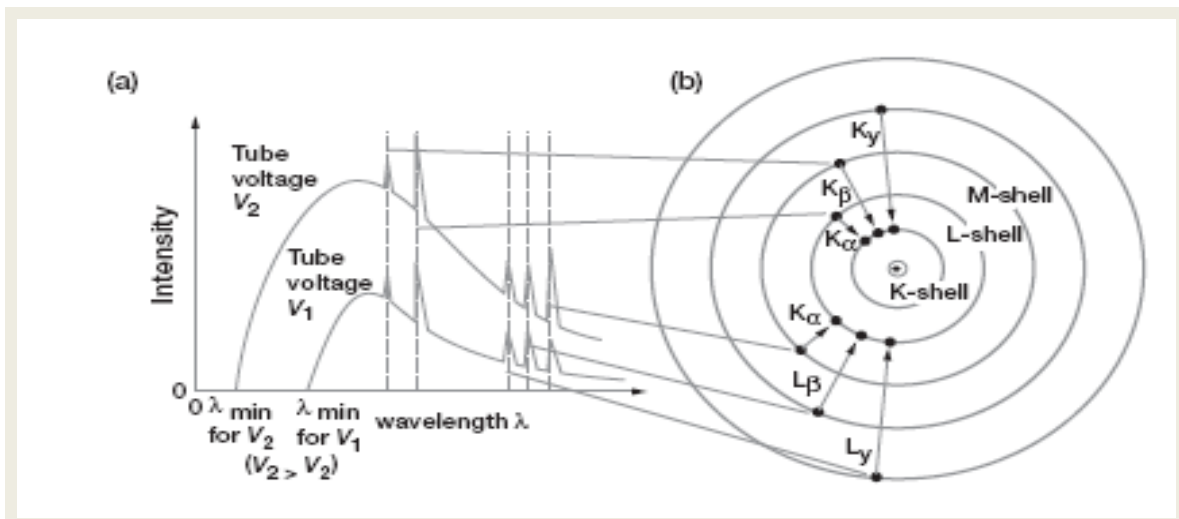

### Exercise 3: X-Rays

- Describe with the aid of a diagram, the construction and principle of operation of an x-ray tube.
- What is the thermionic effect and how is this used in an x-ray tube?
  - Why is the anode usually made to rotate when an x-ray tube is operating?
  - The anode normally consists of a tungsten target embedded in copper. Why are these two materials chosen?
- Sketch a graph of the intensity of x-rays produced against their frequency. Discuss each of the significant features of the graph and the physical principles that give rise to these features.
  - How would the graph change if:
    - a different material was used for the target
    - the current through the heated filament was increased
    - the accelerating potential was increased?
- X-rays are created by accelerating electrons from a cathode across a  $6.00 \times 10^4$  V p.d. Find the:
  - energy of each electron (in eV and J)
  - final speed of each electron (ignore relativistic effects)
  - minimum wavelength of x-ray photons created by the collision of the electrons with the target.
- What potential difference is needed to accelerate electrons in order that x-rays of wavelength  $1.00 \times 10^{-10}$  m are produced?
- An x-ray has a wavelength of 1.00 nm whereas blue light is 400.0 nm. How many photons of blue light would be needed to equal the energy of an x-ray photon?
- An x-ray tube operates at 45,000 V. The most probable wavelength of x-ray produced,  $\lambda_P$  is twice that of the minimum wavelength  $\lambda_M$ . Find the most probable wavelength produced.
- An x-ray tube accelerates electrons across a potential difference of 70 000 V.
  - Find the velocity of the electrons just before they collide with the target.
  - What is the de Broglie wavelength of such electrons?
  - Compare your answer to b to the size of an atom ( $10^{-10}$  m). Is an electron likely to collide with an atom in the target?
- Why do x-rays have a maximum frequency for a given accelerating voltage?
- A student claims that the photoelectric effect is the opposite process to the production of x-rays. What would your comment about this statement be?

### Answers

- $6 \times 10^4$  eV,  $9.6 \times 10^{-15}$  J
  - $1.5 \times 10^8$  ms<sup>-1</sup>
  - $2.1 \times 10^{11}$  m
- $1.24 \times 10^4$  V
- 400
- $5.5 \times 10^{-11}$  m (Hint: find the minimum wavelength first.)
- $1.6 \times 10^8$  ms<sup>-1</sup>
  - $4.6 \times 10^{-12}$  m

